

ALL DIMENSIONS IN mm

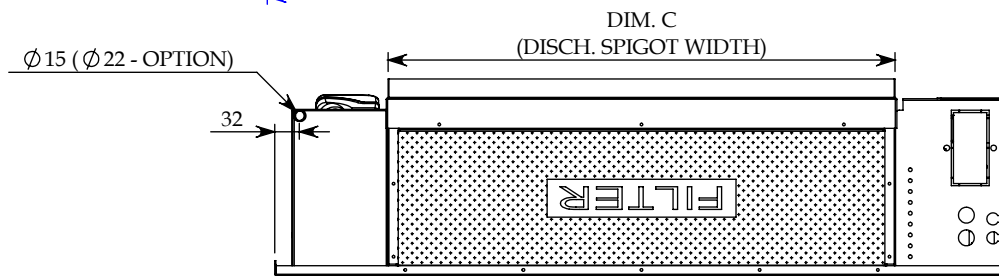

FCU SIZE	DIM. A	DIM. B	DIM. C	DIM. D
MODEL 100	970	735	670	1000
MODEL 200 / 250	1270	1035	970	1300
MODEL 300	1570	1335	1270	1600
MODEL 400	1870	1635	1570	1900
MODEL 500 / 550	2170	1935	1870	2200

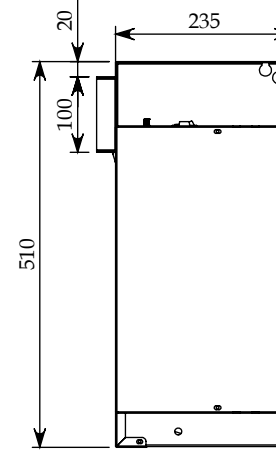
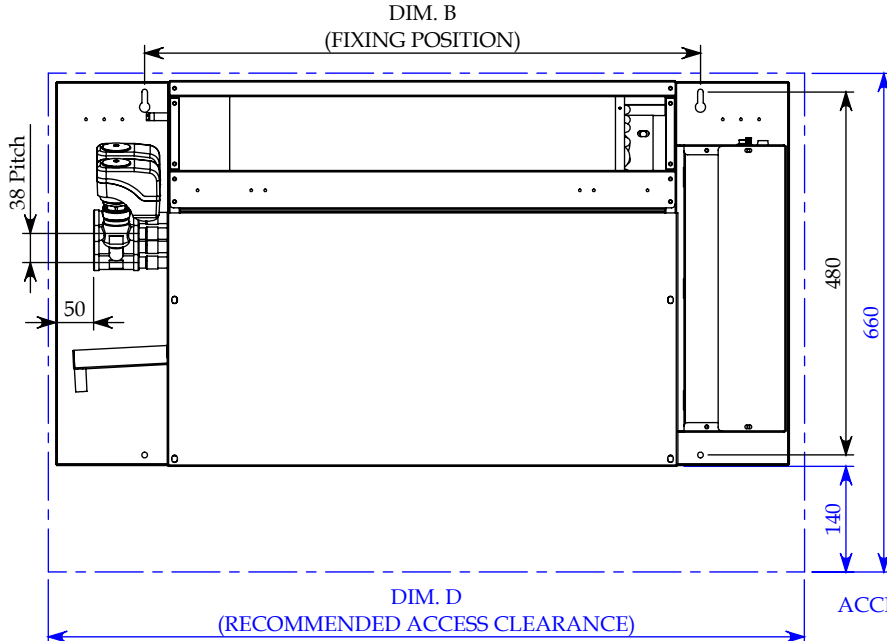
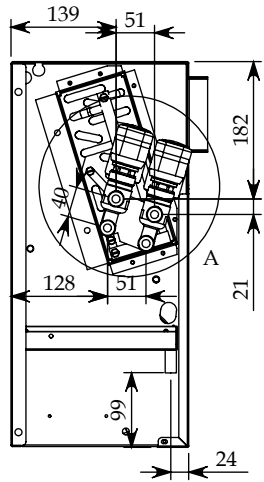
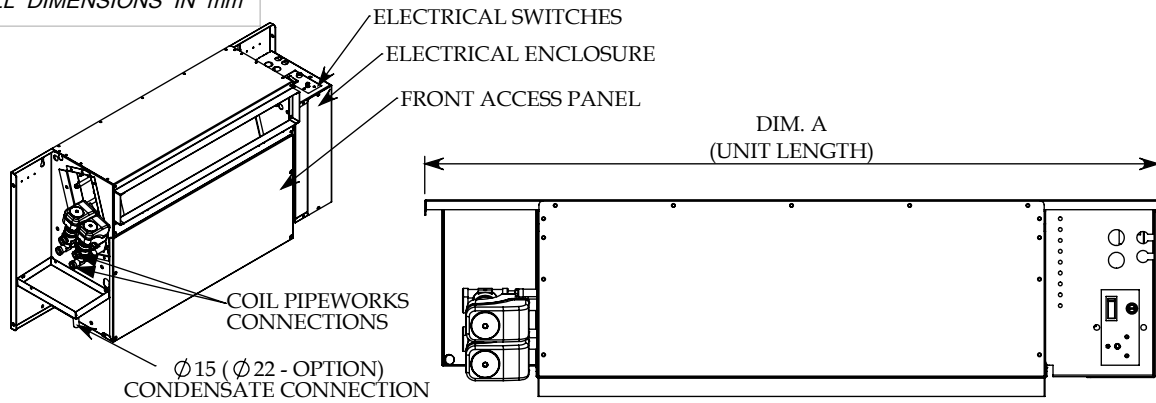
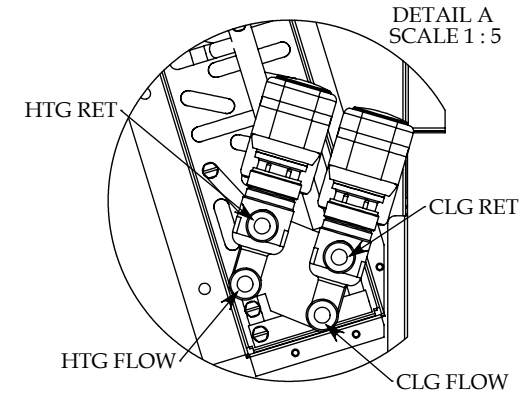

ACCESS DOES NOT NEED TO BE A SINGLE PANEL

GENERAL ARRANGEMENT DWG.
EVOVERT - NEPTUNE
FAN COIL UNIT

LEFT HAND
FAN COIL UNIT SHOWN

REV	DESCRIPTION	INIT	DATE
E			
D	Coil Orientation Amended. Unit Height Increased.		05/10/2017
C	Electrical Enclosure Design Changed.	PRB	16/07/2015
B	Ø22 Condensate Connection Option Added. Coil Pipe Orientation Note Removed.	PRB	13/05/2014
A	Drawing Layout Amended	PRB	26/06/2013



TITLE
EVOVERT Vertical Chassis Fan Coil Unit
Standard - Bottom IN / Front DIS

DRAWN BY	PRB	DATE	29/01/2013	SCALE 1:10
CHECKED BY	MPA	DATE	29/01/2013	
DRAWING NO.			REV	PAGE
GS0091			D	1 of 1